

# PRODUCT INFORMATION PACKET

FASCO®

Model No: D367

Catalog No: D367

Fan Coil & Air Conditioner Motor, 1/10 - 1/15 - 1/30 HP, 1 Ph, 60 Hz, 115 V, 1550 RPM, 3 Speed,  
3.3" Diameter, OAO



Regal and Fasco are trademarks of Regal Rexnord Corporation or one of its affiliated companies.  
©2024 Regal Rexnord Corporation, All Rights Reserved. MC017097E

RegalRexnord



**Nameplate Specifications**

Phase	1	Output HP	1/10 - 1/15 - 1/30 Hp
Output KW	0.07 kW	Voltage	115 V
Speed	1550 rpm	Service Factor	1
Frame	3.3	Enclosure	Open Air Over
Thermal Protection	Thermally Protected	Ambient Temperature	40 °C
Frequency	60 Hz	Current	2.7-2.1-1.7 A
Duty	Air Over	Insulation Class	B
UL	Recognized	CSA	Y
CE	N	Number of Speeds	3

**Technical Specifications**

Electrical Type	Shaded Pole	Starting Method	Across The Line
Poles	4	Rotation	Reversible
Mounting	Extended Studs	Drive End Bearing	Sleeve
Opp Drive End Bearing	Sleeve	Frame Material	Steel
Shaft Type	Flat	Overall Length	15.19 in
Frame Length	3.40 in	Shaft Diameter	0.313 in
Shaft Extension	5.75 in		
Outline Drawing	71636388	Connection Drawing	SEE OUTLINE

This is an uncontrolled document once printed or downloaded and is subject to change without notice. Date Created:02/08/2024

D

D

C

C

B

B

A

A

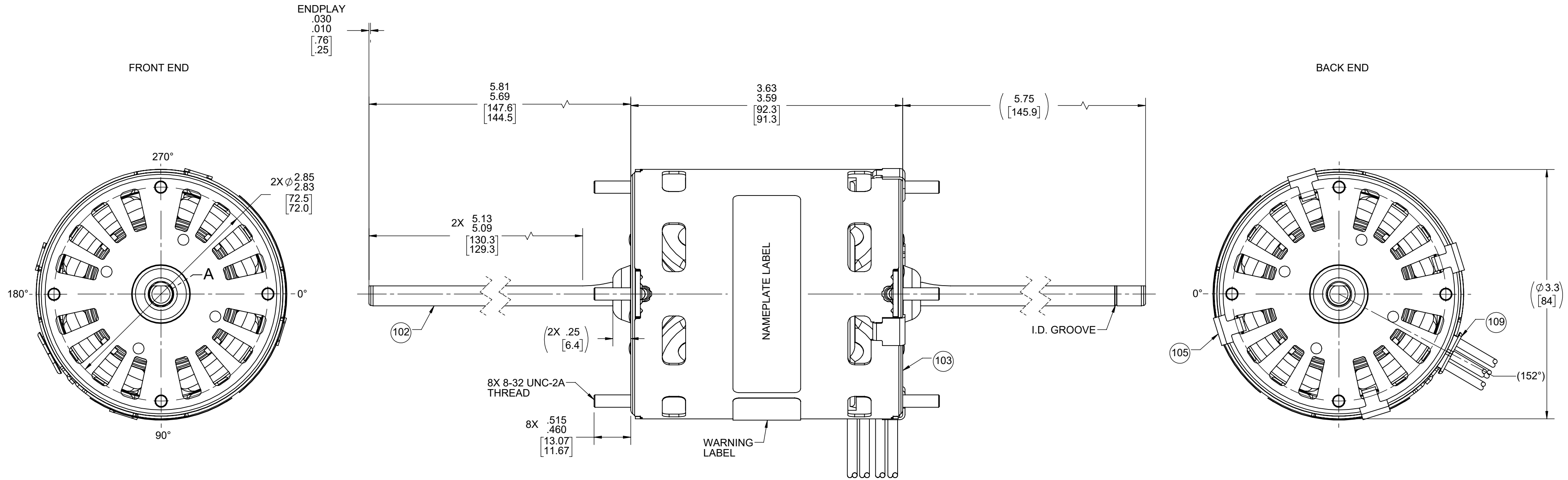

LEAD MATERIAL  
 18 GA. 125°C 2/64 INSUL.  
 X-LINKED POLY.  
 19.00/17.00 [482.6/431.8]  
 W/FLAG TERMS.  
 AMP 42742-2

61305568

**SAFETY WARNING**  
 This motor must be grounded in accordance with local or national electrical codes to prevent possible injury due to electrical shock

**AVERTISSEMENT DE SÉCURITÉ**  
 Ce moteur doit être fondée sur conformément à la réglementation locale ou national électrique codes pour prévenir d'éventuelles blessures en raison de choc électrique

00464072 00469053

**FASCO™**

Assembled In Mexico  
 No. 71636388 TYPE U63B1 T.P. AO  
 115 V 60 Hz Class B 2.7/2.1/1.7 A  
 Model D367 1550 RPM Max Amb: 40°C  
 1/10-1/15-1/30 HP LR6319

Connection Diagram  
 Wht — Common  
 Blk — High  
 Blu — Med  
 Red — Low

61299553

- NOTES:  
 1. MOTOR HAS 416 SS SHAFT.  
 2. NO PACKAGING TAPE OVER CARTON LABEL.

CUSTOMER:	FASCO DIST.	APPLICATION:	WINDOW AIR COND.
CUSTOMER PN:	D367	MOTOR WEIGHT:	5.19 LBS.
		ENVIRONMENT:	DAMP
MOTOR TYPE		REFERENCE SAMPLE	
SHADED POLE			
B	LA	FR	A
00	63	30	V
S	C	E	B
08	CC	7	3
A			0
TYPICAL PERFORMANCE AT 115 VOLTS 60 HZ			
IDLE		LOADED	
LOCKED		BREAK	
MOTOR SPEED	RPM	AMP	WATT
HIGH	1779	1.99	106
MED	1779	1.40	81
LOW	1775	.98	59

DRAWING REVISION AD	REVISION BY MLS	REV DATE/© DATE 7/11/2023	TOLERANCES (EXCEPT AS NOTED): DEC. INCH mm ANGLE	DRAWN BY MLS	Regal Beloit America, Inc.
REQUEST NUMBER ECR-0226918	APPROVED BY SDM	DATE 7/11/2023	.X ±0.1 [±3] .XX ±0.01 [±0.3] .XXX ±0.005 [±0.13] .XXXX ±0.0005 [±0.013]	DATE 9/18/2017	
REQUEST NUMBER DESCRIPTION PICTORIALLY ADD WARNING LABEL TO MOTOR			REMOVE BURRS & BREAK SHARP EDGES: .003/.015 [ .08/.38] X 45° CORNER FILLETS: R.02 [ .5] MACHINED SURFACES: .125 / mm 3.2 / INCH	APPROVED BY SDM	DESCRIPTION OUTLINE MOTOR ASSY
COPYRIGHT (PER REVISION DATE) REGAL BELOIT AMERICA, INC. ALL RIGHTS RESERVED. PROPRIETARY AND CONFIDENTIAL INFORMATION - THIS DOCUMENT IS THE PROPERTY OF REGAL BELOIT AMERICA, INC. (OWNER) AND CONTAINS OWNER'S PROPRIETARY INFORMATION. ANY PERSON, CORPORATION OR OTHER FIRM RECEIVING IT IS DEEMED, BY RECEIVING IT, TO AGREE THAT IT, AND/OR ANY PART OF IT, SHALL NOT BE DISCLOSED TO ANY PERSON, CORPORATION OR OTHER ENTITY, DUPLICATED, AND/OR USED, EXCEPT AS EXPRESSLY APPROVED IN WRITING IN ADVANCE BY OWNER. THIS DOCUMENT SHALL BE RETURNED TO OWNER UPON REQUEST. IT MAY BE SUBJECT TO CERTAIN RESTRICTIONS UNDER APPLICABLE EXPORT CONTROL LAWS AND REGULATIONS.			mm DIMENSIONS IN [BRACKETS] ARE FOR REFERENCE ONLY	DATE 9/18/2017	MATERIAL
THIRD ANGLE PROJECTION			SIZE C	DRAWING NUMBER 71636388	PROCESS/FINISH BLACK
				SHEET 1 OF 2	

4

3

2

1

- NOTES:
1. STAKE STATOR TO MAIN FRAME PER 88830264.
  2. MAXIMUM TORQUE REQUIRED TO TURN MOTOR SHAFT IS 3/8 INCH-OUNCE.
  3. MAKE-UP WASHERS ARE TO BE ADDED OR DELETED TO ACHIEVE REQUIRED ENDPLAY.

FRONT END

BACK END

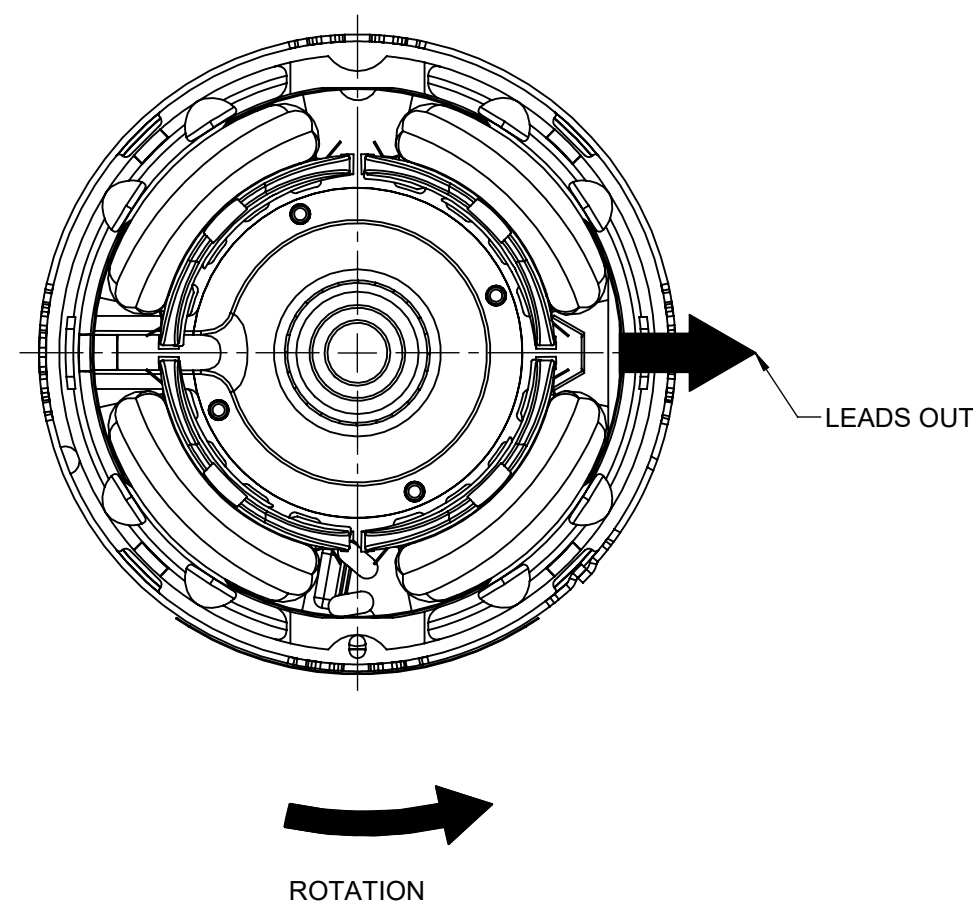
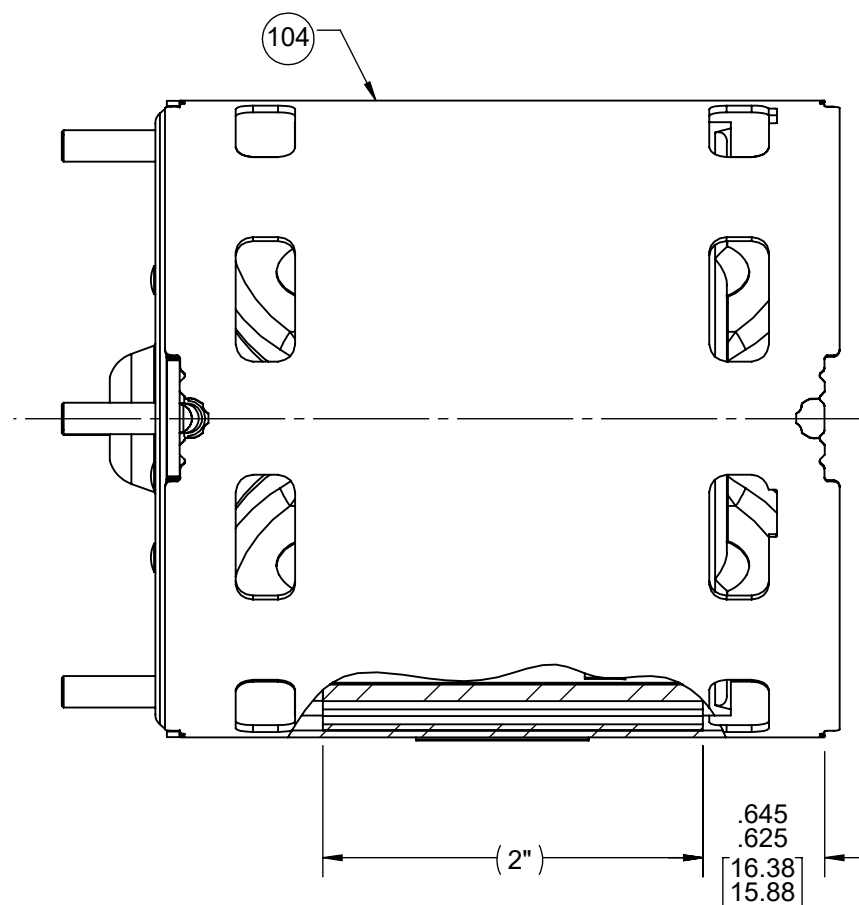

PACKING SPECIFICATIONS

1. PACK PER 88834200. 1 PER CONTAINER, 7 LAYERS PER PALLET, 18 CONTAINERS PER LAYER, 126 MAX. PER PALLET.
2. PLACE (1) FILLER TUBE OVER EACH SHAFT EXTENSION. PLACE MOTOR IN CARTON, LEADS DOWN, CLOSE FLAPS AND TAPE. PLACE LABEL ON END OF CARTON.
3. PLACE (1) FLAT PAD ON PALLET AND (1) BETWEEN EACH LAYER. PLACE (1) FLAT PAD ON TOP LAYER OF PALLET BEFORE STRETCH WRAP.
4. CARTON LABELS MUST ALL FACE ONE DIRECTION TOWARD THE OPEN END OF THE PALLET. SEE 88834408.

DRAWING REVISION AD	REVISION BY MLS	REV DATE/DATE 7/11/2023	TOLERANCES (EXCEPT AS NOTED): DEC. INCH mm ANGLE	DRAWN BY MLS	Regal Beloit America, Inc.
REQUEST NUMBER ECR-0226918	APPROVED BY SDM	DATE 7/11/2023	.X ±0.1 [±3] ±1° .XX ±0.01 [±0.3] .XXX ±0.005 [±0.13] .XXXX ±0.0005 [±0.013]	DATE 9/18/2017	
REQUEST NUMBER DESCRIPTION PICTORIALLY ADD WARNING LABEL TO MOTOR			REMOVE BURRS & BREAK SHARP EDGES: .003/.015 [.08/.38] X 45° CORNER FILLETS: R.02 [5] MACHINED SURFACES: .125/ mm 3.2 INCH/mm	APPROVED BY SDM	DESCRIPTION OUTLINE MOTOR ASSY
COPYRIGHT (PER REVISION DATE) REGAL BELOIT AMERICA, INC. ALL RIGHTS RESERVED. PROPRIETARY AND CONFIDENTIAL INFORMATION - THIS DOCUMENT IS THE PROPERTY OF REGAL BELOIT AMERICA, INC. (OWNER) AND CONTAINS OWNER'S PROPRIETARY INFORMATION. ANY PERSON, CORPORATION OR OTHER FIRM RECEIVING IT IS DEEMED, BY RECEIVING IT, TO AGREE THAT IT, AND/OR ANY PART OF IT, SHALL NOT BE DISCLOSED TO ANY PERSON, CORPORATION OR OTHER ENTITY, DUPLICATED, AND/OR USED, EXCEPT AS EXPRESSLY APPROVED IN WRITING IN ADVANCE BY OWNER. THIS DOCUMENT SHALL BE RETURNED TO OWNER UPON REQUEST. IT MAY BE SUBJECT TO CERTAIN RESTRICTIONS UNDER APPLICABLE EXPORT CONTROL LAWS AND REGULATIONS.			DATE 9/18/2017	REFERENCE	MATERIAL
			mm DIMENSIONS IN [BRACKETS] ARE FOR REFERENCE ONLY	THIRD ANGLE PROJECTION	PROCESS/FINISH BLACK
				SIZE C	DRAWING NUMBER 71636388
					SHEET 2 OF 2

4

3

2

1